

# Sensor Assignment to Missions in a Coalition Context: The SAM Tool

A. Preece\*, D. Pizzocaro\*, K. Borowiecki\*, G. de Mel†, M. Gomez†, W. Vasconcelos†,  
 A. Bar-Noy‡, M. P. Johnson‡, T. La Porta§, H. Rowaihy§, G. Pearson¶, T. Pham||

\*Cardiff University, UK; contact email: a.d.preece@cs.cardiff.ac.uk; †University of Aberdeen, UK

‡City University of New York, USA; §Pennsylvania State University, USA

¶DTSL, Great Malvern, UK; ||US Army Research Laboratory, Adelphi MD, USA

Dynamic, mission-focussed intelligence, surveillance and reconnaissance (ISR) requires agile management of information-provisioning capabilities. This includes rapid assembly of sensing systems, highly efficient resource management, and an ability to configure and reconfigure, task and retask, ISR systems in a robust way [1]. We consider the problem of *sensor-mission assignment* as that of allocating a collection of ISR assets (including sensors and sensor platforms) to a set of *tasks* comprising a mission, in an attempt to satisfy the ISR requirements of those tasks. We assume that tasks originate from ad hoc communities of interest (CoIs) within the coalition [1], and that coalition members share ISR assets to some extent.

Figure 1 shows our approach to the sensor-mission assignment problem [2]. We assume that the information requirements of mission tasks can be captured in a machine-processable way and that these can be “fitted” to available types of assets, to yield a set of fit-for-purpose types of ISR solutions. Note that we deal with heterogeneous task and sensor types, and there is a many-to-many relationship between these: the same kind of task can be accomplished in several different ways; the same type of asset can serve many different kinds of tasks. We envisage this normally happening at mission-planning time. Then, individual instances of the assets are allocated to the tasks: this can happen at planning time, but for maximal agility should be done at run-time. Most importantly, the approach supports run-time *reallocation* of assets, to cope with the emerging situation, guided by the range of feasible alternative solutions determined at planning time. This process requires a highly reconfigurable sensor network environment, which also delivers the collected information, and feeds back monitoring data on the status of the assets. Changes in the task and asset sets may result from this received information and data: new information requirements may be generated, or monitoring may reveal that a sensor has failed.

Our approach to sensor-mission fitting is founded on the use of *ontologies* to represent the capabilities required by tasks and provided by assets, and reasoning to determine logically-sound matches. Ontologies define formally the semantics of a set of terms, allowing automatic reasoning to be performed using the terms, in a manner consistent with their real-world interpretation. There is already a sizeable amount of work done in providing descriptive schemas and ontologies for sensors, sensor platforms, and their properties (e.g. [3], [4]). There are also several well-known structured descriptions of tasks in the military missions context, e.g. the US Universal Joint Task

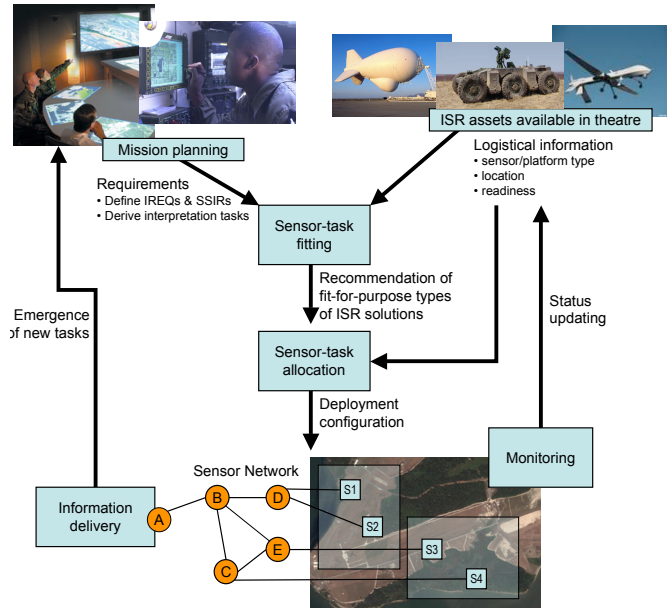

Fig. 1. An approach to sensor-mission assignment

List (UJTL)[5] and the UK JETL/METL task lists.

Based largely on pre-existing ontologies, we have identified a collection of concept hierarchies relevant to the ISR domain. A sample of these is shown in Figure 2, including definitions of (a) platforms and (b) sensors.

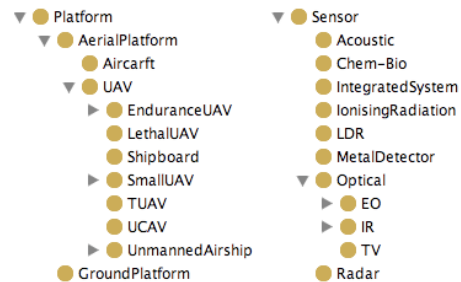

Fig. 2. Sample concept taxonomies relevant to the ISR domain

We have implemented a pilot application called SAM (Sensor Assignment to Missions) as an illustration-of-concept to test and refine our approach: see Figure 3. A user logs-in as a member of a particular CoI. In our simplified example, there are two, corresponding to the “UK” and “US” members of a two-country coalition. The user is able to select one

or more AoIs on a map (left panel) and, for each, to select multiple ISR requirements (top-right panel) from the capability ontologies. SAM is implemented as a Web application in Java and uses the Pellet reasoner [6] to infer a set of sensor/platform configurations, each of which can satisfy all the requirements (bottom-right). Before performing reasoning, the SAM application queries inventory catalogues to determine what types of platforms and sensors are actually available, so it can recommend sensor/platform configurations including the most specific types that are potentially deployable. In doing this, it takes into account access policies on these resources, including ownership (note that the figure shows UK/US ownership of assets in the bottom-right panel) and whether the user has sufficient privileges to task those assets (shown by the “lock” icon next to the asset types). While simple, this mechanism is intended as an expansion point to allow the incorporation of more sophisticated access policies in future, such as those described in [1]. Figure 4 shows how the SAM application works in a distributed fashion in a multiple-CoI context, with separate UK and US users, each having access to a private catalogue of ISR assets ( $Cat_{UK}$  and  $Cat_{US}$  respectively) and also a coalition-wide catalogue of shared assets ( $Cat_{Co}$ ). Our prototype implementation uses the ITA Sensor Fabric [7], allowing the SAM application to dynamically configure a set of selected sensors on the network, and allowing the user to subscribe to these in order to receive the required information and intelligence (I2). This is shown in the lower part of Figure 4.

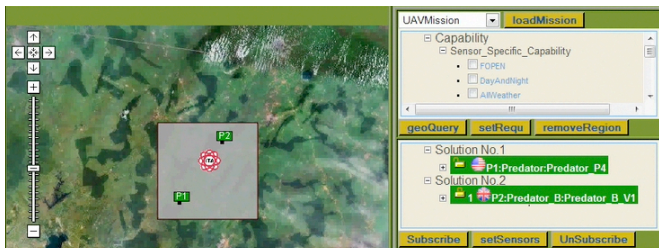

Fig. 3. Screenshot of the Sensor Assignment to Missions (SAM) application

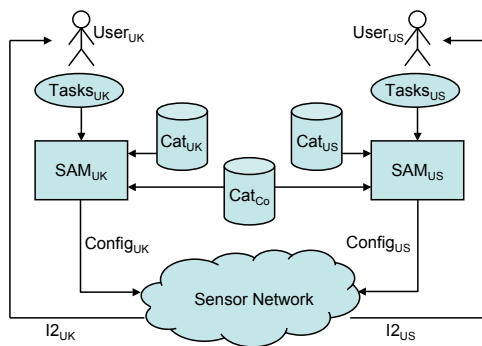

Fig. 4. A simple coalition use of the SAM application

The demonstration will show how:

- 1) a commander’s information requirements (IREQs) can be specified in a machine-processable way;
- 2) these tasks can be matched against available sensor and platform ISR asset types using our ontology-based approach;
- 3) individual instances of sensor/platform assets can be allocated to tasks, taking into account access rights on the assets;
- 4) a user can subscribe to these instances and receive information delivered via the ITA Fabric;
- 5) if an asset fails, the system can recommend an alternative, dynamically at run-time.

We will demonstrate the prototype solution in the context of a main supply route (MSR) scenario, where a commander wishes to be informed of suspicious vehicle activity on the route. Available assets will include UAVs capable of providing IMINT, and acoustic arrays providing ACINT, both able to identify vehicle types. We will show how access rights restrict the commanders choice of assets, and also how the approach allows dynamic reallocation of assets when necessary (e.g. switching to an ACINT solution if monitoring indicates that the UAV has become inoperable).

The SAM tool has been demonstrated to stakeholders in the UK MoD and US ARL, with positive feedback. The ability of the tool to generate explanations and support “what-if” explorations of potentially-available ISR solutions has been highlighted as particularly desirable, as has the incorporation of various kinds of policy. The use of ontologies offers potential for restricted “advertising” of assets within the coalition. As highlighted in [1], it is conceivable that a coalition member may not want to expose the full capabilities of its sensors.

**Acknowledgments** This research was sponsored by the US Army Research Laboratory and the UK Ministry of Defence and was accomplished under agreement W911NF-06-3-0001. The views contained in this paper are those of the authors and should not be interpreted as representing the official policies, either expressed or implied, of the US ARL, the UK MoD, or the US or UK Governments. The US and UK Governments are authorized to reproduce and distribute reprints for Government purposes notwithstanding any copyright notation hereon.

## REFERENCES

- [1] T. Pham, G. Cirincione, D. Verma, and G. Pearson, “Intelligence, surveillance, and reconnaissance fusion for coalition operations,” in *Proc 11th International Conference on Information Fusion*, 2008.
- [2] A. Preece, M. Gomez, G. de Mel, W. Vasconcelos, D. Sleeman, S. Colley, G. Pearson, T. Pham, and T. L. Porta, “Matching sensors to missions using a knowledge-based approach,” in *SPIE Defense Transformation and Net-Centric Systems 2008 (SPIE Defense and Security Symposium)*, 2008.
- [3] D. Russomanno, C. Kothari, and O. Thomas, “Building a sensor ontology: A practical approach leveraging ISO and OGC models,” in *Proceedings of the International Conference on Artificial Intelligence*, 2005, pp. 637–643.
- [4] L. Bermudez, J. Graybeal, and R. Arko, “A marine platforms ontology: Experiences and lessons,” in *Proceedings of the ISWC 2006 Workshop on Semantic Sensor Networks*, Athens GA, USA, 2006.
- [5] UJTL Ontology, <http://orlando.drc.com/semanticweb/daml/ontology/condition/ujtl/condition-ont>.
- [6] Pellet OWL DL Reasoner, <http://pellet.owldl.com/>.
- [7] F. Bergamaschi, D. Conway-Jones, C. Gibson, and A. Stanford-Clark, “A distributed test framework for the validation of experimental algorithms using real and simulated sensors,” in *First Annual Conference of the International Technology Alliance (ACITA 2007)*, 2007.